

# AI·SONIC

*Finnish audio design*

## OWNERS MANUAL

### S1-CX69.2

COMPONENT / COAXIAL  
SPEAKER SET



# Introduction

Thank you for choosing AI-SONIC product!

Finnish AI-SONIC brand is developed by long term car-audio enthusiasts.

With our knowhow and passion, we have created product line that meets the needs for both competition and everyday usage.

Our team have spent countless hours to make your listening moments as an pleasant experience, and our R&D goal is to produce best possible quality and performance for every price category without compromises.

## S1-CX69.2

- \* 6x9" 2-Way Component Speaker System with coaxial option
- \* Sandblasted Stainless Steel Basket
- \* Black pressed paper Cone Rubber surround
- \* 1.0 inch ASV Voice Coil
- \* 20mm Silk Dome Neodymium tweeter
- \* 2-way passive crossover with rubber housing

## Technical specification

S1-CX69.2	MODEL	S1-W69.2	S1-T20
	FS	67 Hz	1400 Hz
	Efficiency (SPL)	91 dB	89 dB
	Qts	0,77	n/a
	Vas	17 L	n/a
	Impedance	4 Ohm	4 Ohm
	Frequency response	35 Hz-25 kHz	2 kHz - 25 kHz
	Power recommendation	20-150W	20-50W

# COMPONENT TO COAXIAL SETUP

## step 1.

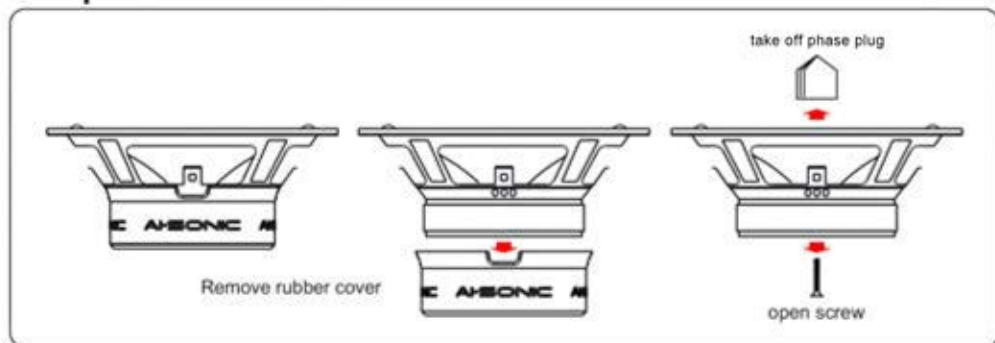

## step 2.

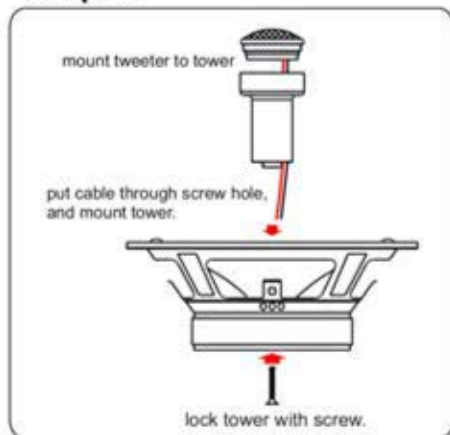

## step 3.

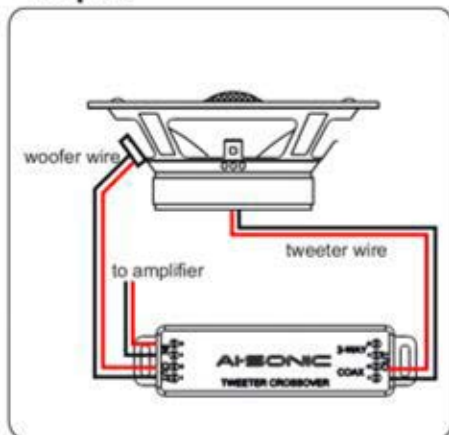

## Component setup

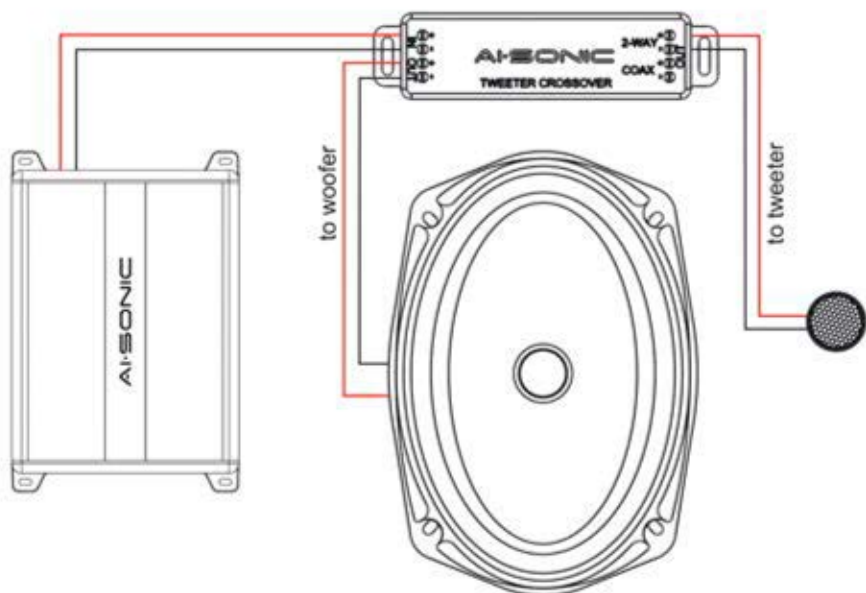

## Coaxial setup

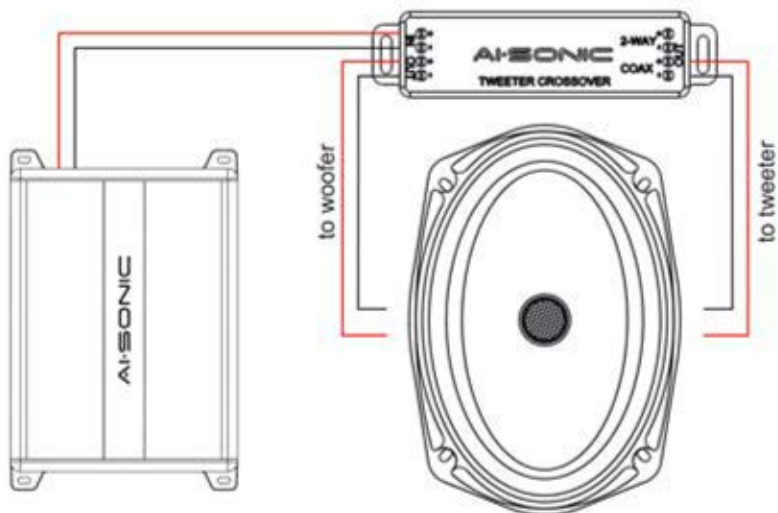

# Dimensions

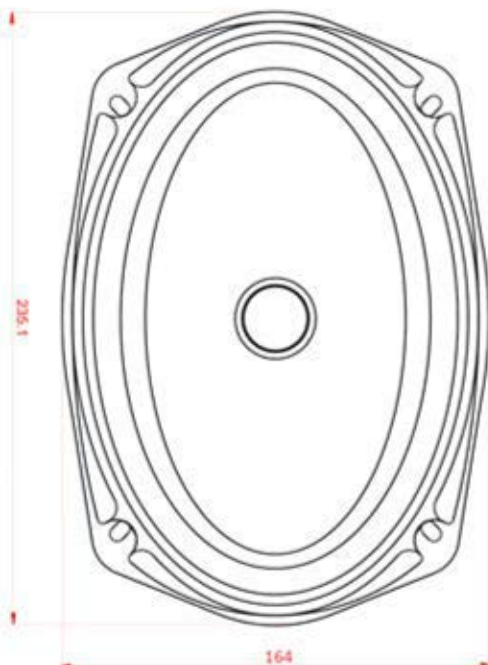
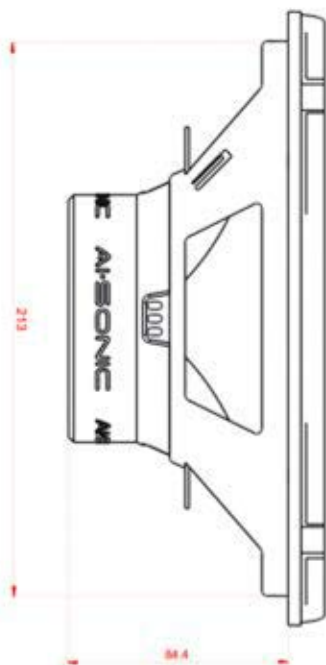

36



33



# Tweeter setup for component system

These values are recommendations by our own experience.

When tweeter is mounted towards listener ● (on axis),  
tweeter level adjustment should be -3dB.

When mounted towards center of vehicle ○ (off axis),  
tweeter level adjustment should be 0dB.

On dashmount ● (off axis) installation, tweeter will get window reflection, and  
on many cases needs to be connected with inverted polarity\*.

These setups are just recommendations.  
Try both ways and choose best for you.

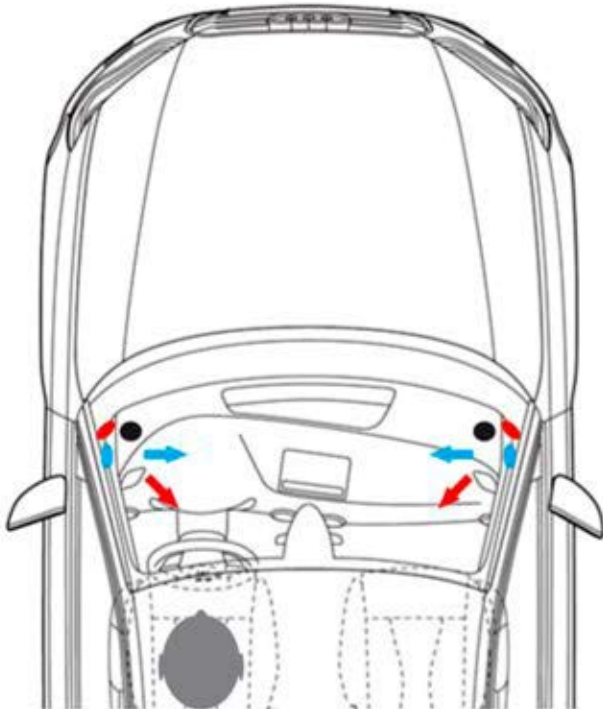

Crossover (tweeter) wiring for inverted polarity



# AI·SONIC

*Finnish audio design*

AI-SONIC is a trademark of  
Oy AI-Group Ab  
info@audiolimport.fi  
www.ai-sonic.com



# Important Safety instructions

Please read all warnings found in this manual. They inform you of the potential danger of personal injury or damage to property.

**Our products are intended for use only by those possessing the necessary specialized knowledge. The relevant safety regulations regarding related auto parts, the regulations on internal vehicle safety, as well as the regulations of the authorized vehicle manufacturers should be followed diligently.**

## Hearing damage

Continuous, excessive exposure to sound pressure levels in excess of 85dB can cause a loss of hearing. AI-SONIC components are capable of producing sound pressure levels greater than 85dB.

## Volume and Driver Awareness

Use of sound components can impair your ability to hear necessary traffic sounds and may constitute a hazard while driving your automobile.

AI-SONIC accepts no liability for hearing loss, bodily injury or property damage as a result of use or misuse this product.

## Working on Automobile

Do not use your automobile until all components of the loudspeaker system have been secured to the interior framework. Failure to do so may turn a component into a dangerous, flying projectile during a sudden stop or accident.

Do not drill or drive screws through any vehicle interior or carpeted floor before inspecting the underside for potential punctures to control lines or cables. Be sure to avoid all fuel lines, brake lines, electrical cable or oil lines when planning the installation.

Before beginning installation of the loudspeaker system remove the minus connector [-] from the automobile battery in order to avoid possible short circuits.

Use care when removing interior trim panels. Car manufacturers use a variety of fastening devices that can be damaged in the disassembly process.

If sheet metal must be cut or removed contact your authorized car dealer for professional advice.

**By damage to supporting body structures the safety certificate may be withdrawn.**

## ! Shock Hazard !

**Do not touch the connectors when the system is running!**